

DE Gleitschienen-Türschließer
Montageanleitung

EN Door closer with slide rail
Assembly instructions

FR Ferme-porte à glissière
Notice de montage

ES Cierrapuertas con riel de deslizamiento
Instrucciones de montaje



	Gretsch-Unitas GmbH Baubeschläge Johann-Meus-Str. 3 D-71254 Ditzingen	17
	EN 1154:1996 00184-08 +A1:2002	4 8 2-4 1 1 1 3
Dangerous substances: None		

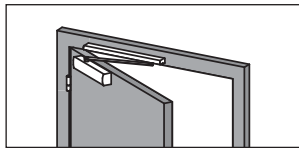

9-50853

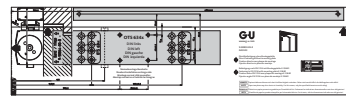

Anschlagsschablone
Mounting template
Gabarit de pose
Plantilla de montaje

1a

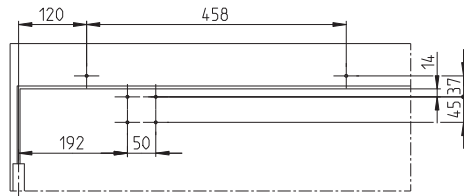

1b

Mit / With /
Avec / Con
9-50864



Bohrlehre (optional)
Drilling jig (optional)
Gabarit de perçage (en option)
Plantilla de taladro (opcional)

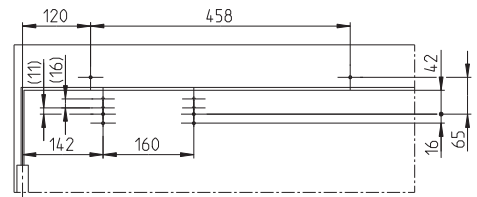
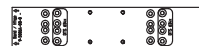

2

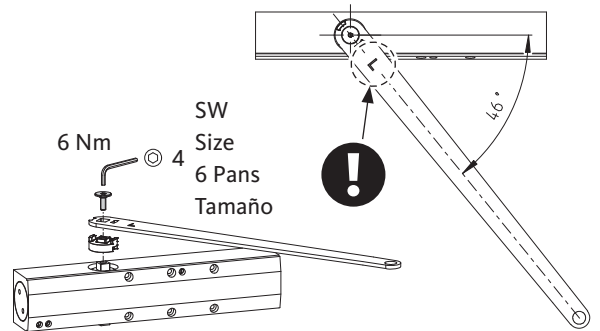
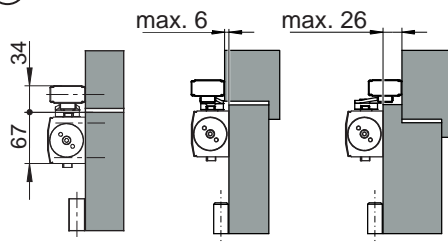

Original-
anleitung

Translation of
the original
instructions

Traduction de la
notice d'origine

Traducción de
las instrucciones
originales

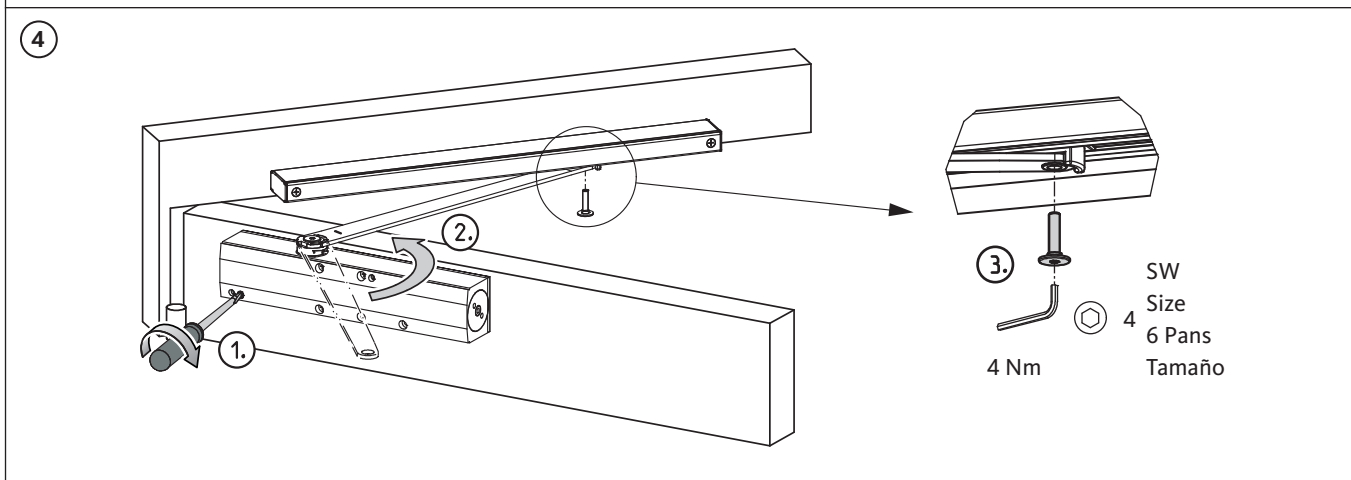
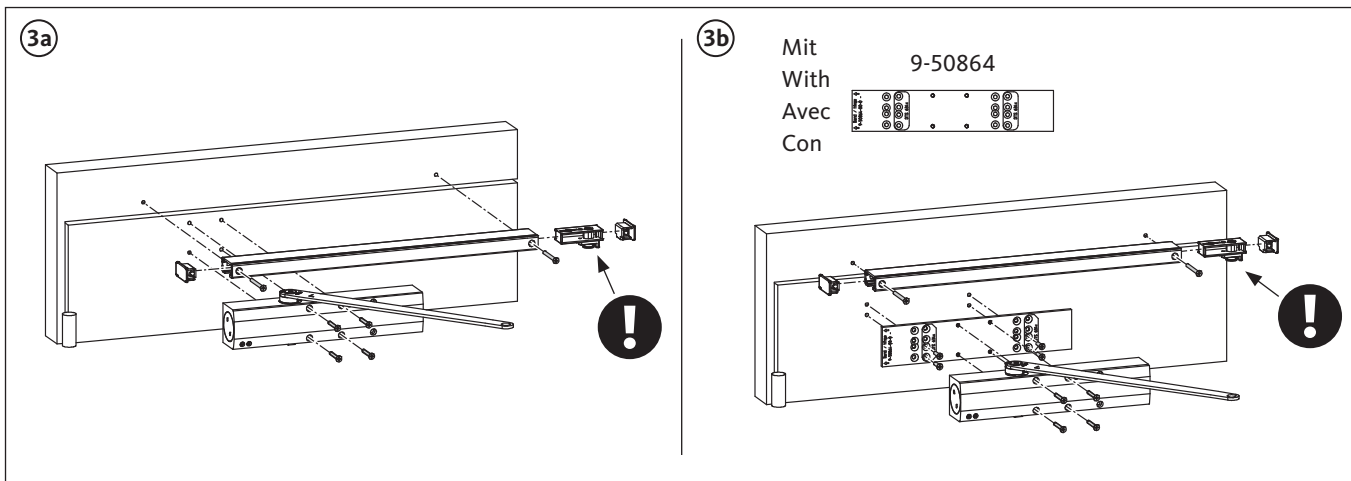

3. SW
Size 4
6 Pans
Tamaño

4 Nm

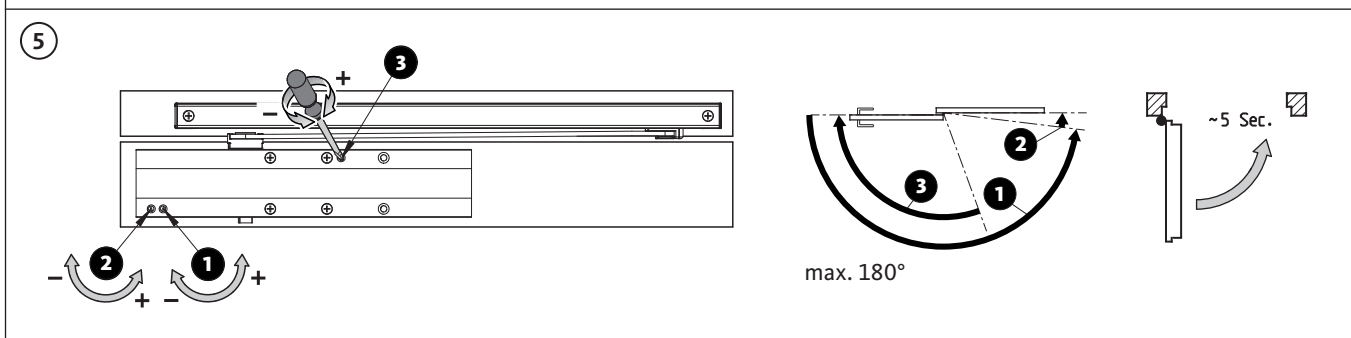

6

SW
Size 5
6 Pans
Tamaño

Schließkraft / Closing force / Force de fermeture / Fuerza de cierre		
EN	B	U
2	≤ 850 mm	-5
3	≤ 950 mm	0
4	≤ 1100 mm	+13

min. EN 3

U = Umdrehungen / Rotations /
Rotations / Rotaciones

B

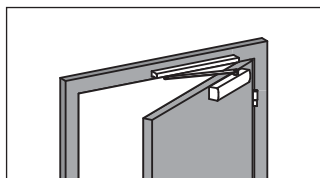

9-50853

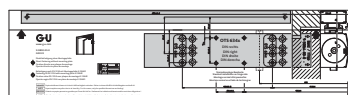

Anschlagsschablone
Mounting template
Gabarit de pose
Plantilla de montaje

1a

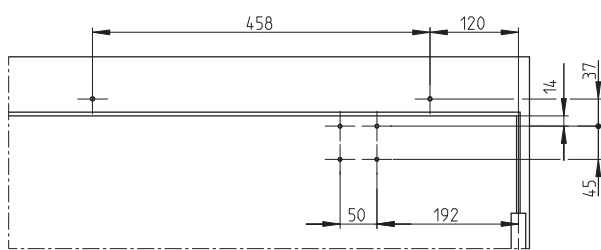

1b

Mit / With /
Avec / Con
9-50864

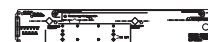

Bohrlehre (optional)
Drilling jig (optional)
Gabarit de perçage (en option)
Plantilla de taladro (opcional)

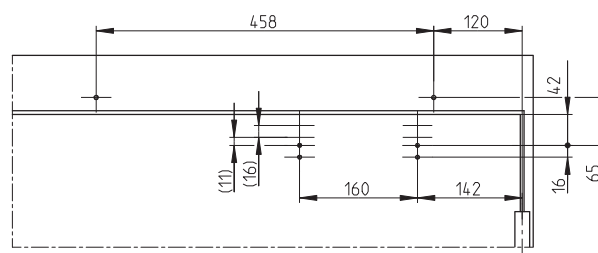
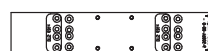

2

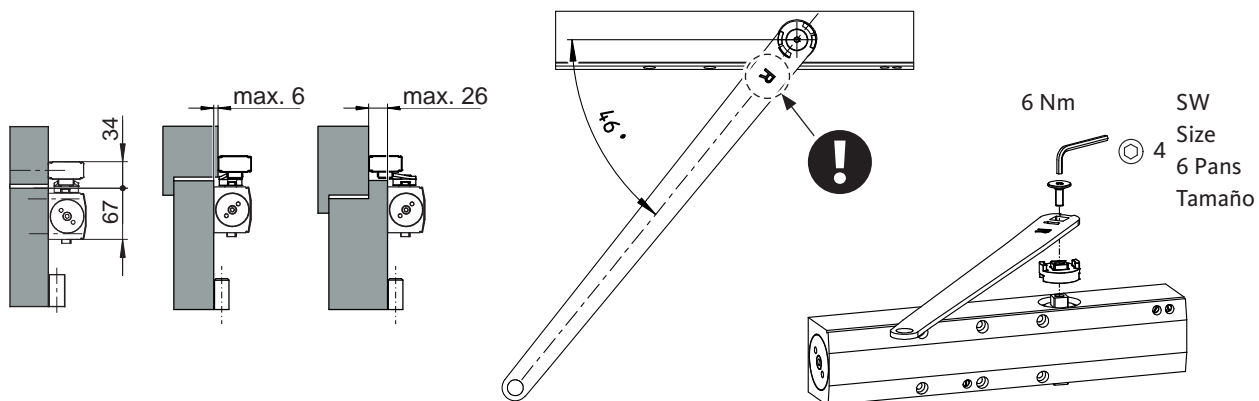

3a

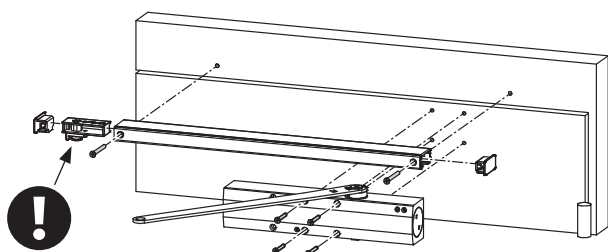

3b

Mit
With
Avec
Con
9-50864

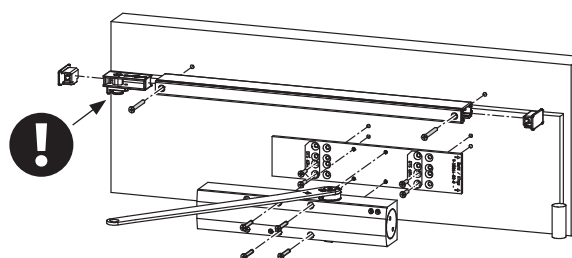
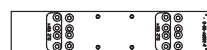



4

4 Nm
SW Size 6 Pans
Tamaño

5

max. 180°
~5 Sec.

6

SW Size 6 Pans Tamaño

Schließkraft / Closing force / Force de fermeture / Fuerza de cierre

EN	B	U
2	≤ 850 mm	-5
3	≤ 950 mm	0
4	≤ 1100 mm	+13

min. EN 3
U = Umdrehungen / Rotations / Rotations / Rotaciones

B

Für das Produkt gilt die **Leistungserklärung 0055-CPR-GU-BKS-Ferco** (Download auf www.g-u.com).

HINWEIS

Beachten Sie auch die "Produktinformation Türschließer OTS | UTS | VTS" (Art.-Nr. 0-46884). Sie finden das Dokument auf "www.g-u.com".

The **Declaration of Performance 0055-CPR-GU-BKS-Ferco** applies to this product (download from www.g-u.com).

NOTE

Also observe the product information 0-46884 "OTS | UTS | VTS – Door closer product information". You will find the document at www.g-u.com.

Pour le produit, la **déclaration de performance 0055-CPR-GU-BKS-Ferco** s'applique (Télécharger sur www.g-u.com).

REMARQUE

Tenez également compte des informations produits 0-46884 "OTS | UTS | VTS – Ferme-porte Information produits". Vous trouverez le document sur www.g-u.com.

La **declaración de rendimiento 0055-CPR-GU-BKS-Ferco** se aplica al producto (Descargar en www.g-u.com).

NOTA

Tenga también en cuenta las informaciones de producto 0-46884 "OTS | UTS | VTS – Cierrapuertas Información del producto". Encontrará el documento en www.g-u.com